

**SINGLE FAMILY RESIDENTIAL ZONE
 PLAN CHECK CORRECTION SHEETS**

(Ordinance No. 184,802 Effective 3/17/17)

Plan Review Date: _____

Plan Check #: _____ Permit Application Number: _____

Job Address: _____

Plan Check Engineer: _____ Phone: _____ Email: _____

This is a supplemental correction sheet. Please see the attached master correction sheet.
 This correction sheet only applies to plan checks submitted on or after March 17, 2017.

These corrections apply to new construction, additions, and major remodels to any Building or Structure on a lot in the R1, R1V, R1F, R1R, RS, RE, or RA zones when not within a designated Hillside Area (Zoning). References to "R1" zones apply to the R1, R1V, R1F, and R1R zones.

Review the following checked information bulletins and forms. Revise plans to show compliance.
 (Copies can be obtained at www.ladbs.org).

- | | | | |
|--|---|--|--|
| <input type="checkbox"/> P/ZC 2002-002 | Heights of Fences in Residential Zones | <input type="checkbox"/> P/ZC 2002-008 | Determination of the Zoning Height of a Building or Structure |
| <input type="checkbox"/> P/ZC 2002-004 | Allowable Projection for Decks and Built-Up Platforms in Required Yards | <input type="checkbox"/> P/ZC 2002-015 | Determining Front Yards, When Subject to the Prevailing Setback Regulation |
| <input type="checkbox"/> P/ZC 2002-006 | Allowable Projections and Improvements in Required Yards | | |

PART I: SETBACK REQUIREMENTS

A. FRONT YARD SETBACK

1. Provide and dimension the required Front Yard setback. (12.08C.1, 12.07.1C.1, 12.07.01C.1 & 12.07C.1)
 - a. The Front Yard setback shall not be less than the prevailing setback. See Information Bulletin P/ZC 2002-015 for additional information.
 - b. Where a prevailing Front Yard setback cannot be established, provide (____) ft. as required in the (____) zone.
2. Not more than 50 percent of a required front yard shall be designed, improved or used for access driveways. All portions of required front yard not used for necessary driveways and walkways, including decorative walkways shall be used for planting and shall not be paved. (12.21C.19(g))

B. SIDE/REAR YARD SETBACKS

1. Provide and dimension on plan a (____) ft. Side Yard setback and a (____) ft. Rear Yard setback as required in the (____) zone. (12.08C, 12.07.1C, 12.07.01C & 12.07C)
 - a. In the calculation of side yard setbacks, any basement containing habitable rooms shall be considered a story. (12.21.1A.8)
2. In all the R1 zones, any occupied rooftop deck shall be set back at least 3 ft. from the minimum required Side Yard setback. This does not apply to any rooftop deck located on the street side of a corner lot. (12.08C.2(d))

3. In all the R1 zones, where the Building or Structure has a side wall that exceeds a height of 14 ft. and has a length of 45 ft. or more, provide an offset/plane break that has a minimum depth of 5 ft., beyond the required Side Yard setback, for a minimum length of 10 ft. See below for plane break diagram (12.08C.2(a))

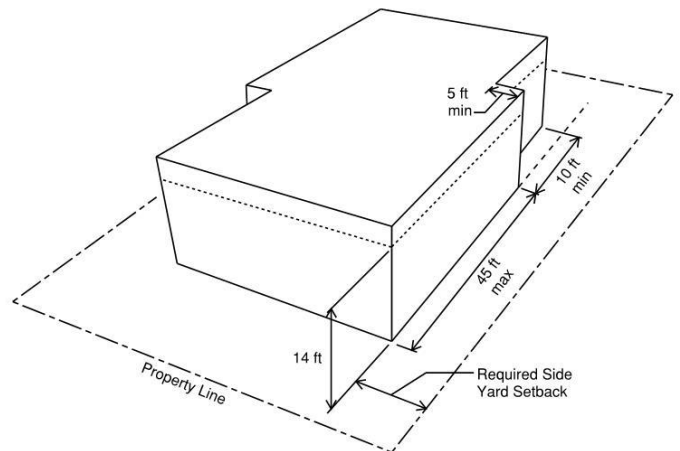

Figure 12.08 C.2.(a): Plane break diagram

As a covered entity under Title II of the Americans with Disabilities Act, the City of Los Angeles does not discriminate on the basis of disability and, upon request, will provide reasonable accommodation to ensure equal access to its programs, services and activities

PART II: Residential Floor Area (RFA) and Lot Coverage

A. MAXIMUM RESIDENTIAL FLOOR AREA

1. Provide a summary of the total site RFA. Clearly indicate the RFA per structure on site and any exemptions used. (See RFA definition in LAMC 12.03)
 - a. Provide key plans of all buildings, clearly identifying all areas considered when calculating the existing and proposed RFA.
 - b. Provide complete cross sections specifying the attic ceiling heights. Portions of attics with a ceiling height of more than 7 ft. shall be included in RFA calculations. Where the attic height exceeds 7 ft., provide floor key plans of the attic and clearly identify these areas with dimensions.
 - c. Provide complete cross sections specifying the ceiling heights. Where the ceiling height exceeds 14 ft., provide floor key plans of the attic and clearly identify these areas with dimensions. The subject areas shall be counted twice in the RFA calculations. The area of stairways and elevator shafts shall only be counted once regardless of ceiling height.
 - d. Any covered parking/driveway areas shall be included in the RFA calculations. Except that:
 - i. A total of 200 sq. ft. per required covered parking space, up to a maximum of 400 sq. ft. may be exempt, if all of said parking is in the rear half of the lot or 55 ft. from a Front Lot Line.
 - ii. Only 200 sq. ft. shall be exempted if said parking is not located as required above.
 - e. All accessory buildings shall be included in RFA calculations. Detached accessory buildings not exceeding 200 sq. ft. may be exempted in the RFA calculations. However, the total combined area of exempted accessory buildings shall not exceed 400 sq. ft
 - f. Porches, patios, and breezeways with a solid roof shall be included in the Residential Floor Area calculations. Porches, patios, and breezeways with a lattice roof shall not be included in the RFA calculations
 - g. The basement area shall be included in the Residential Floor Area calculations when the floor or roof above exceeds 2 ft. in height above the finished or natural grade whichever is lower.
2. Since the lot is Zoned (_____) and the lot area is (_____) sq. ft., the Residential Floor Area Ratio (RFAR) is (_____) and the Residential Floor Area (RFA) is limited to (_____) sq. ft., unless an allowable bonus increase is applicable. See Table A for a summary of the RFAR values.

3. Clearly identify which RFA bonus was used. Note that the RFA bonus is only applicable in the RA, RE and RS zones only and only one bonus increase is allowed per property. Clearly demonstrate on plans compliance with the option used:

(12.07C.5, 12.07.01C.5, & 12.07.1C.5)

 - a. Proportional Stories Option – all other stories are no more than 75% of the "Base Floor" as defined in Section 12.03.
 - b. Front Façade Step Back Option – At least 25% of the building frontage facing the front property line is stepped back at least 20% of the total building depth, rounded to the nearest foot.
4. The total proposed RFA of (_____) sq. ft. exceeds the maximum allowed.

(12.07C.5, 12.07.01C.5 & 12.07.1C.5)

 Max. Allowable RFA per Table A = (_____) sq. ft.
 Total RFA with Bonus = _____
 RFA per Table A + 20% bonus = (_____) sq. ft.

B. VERIFICATION OF EXISTING RFA

1. Provide the following on plans:

(12.07C.6, 12.07.01C.6, 12.07.1C.6 & 12.08C.6)

 - a. Total existing RFA
 - b. Additional RFA
 - c. Total allowable RFA with bonus
 - d. Total proposed RFA with itemized exemptions
2. For additions with cumulative RFA of less than 1,000 sq. ft. constructed after January 1, 2008, or remodels of Buildings built before January 1, 2008, the existing RFA shall be determined based on the following:
 - a. Building records.
 - b. The building square footage shown on the most recent Los Angeles County Tax Assessor's Records. Note that areas of accessory buildings, covered porches/patios, and covered parking spaces are to be included separately.
 - c. Calculations of RFA when a complete set of fully dimensioned plans by a licensed architect or engineer is submitted.
3. For additions of 1,000 sq. ft. or larger and alterations where more than 50% of contiguous exterior walls or roof are not retained, provide a complete set of fully dimensioned plans with area calculations of all the structures on the lot prepared by a licensed architect or engineer to determine the existing/proposed RFA.

C. LOT COVERAGE

1. In the R1V(_____) R1F(_____) R1R(_____) zone, where the lot area is (_____) sq. ft., the maximum allowed lot coverage is (_____)%. (Tables 12.08 C.5(b),(c)&(d))

PART III: Height and Encroachment Plane

A. MAXIMUM HEIGHT LIMITS

1. The height of a building is defined as the distance above grade (see below) to the highest elevation of the building/structure, including parapets.
 - a. Grade is defined as the lowest point of elevation (located within the property) of the finished surface of the ground, paving or sidewalk within 5 feet around the perimeter of the building. Clearly identify this point on the plot plan as the "Datum Point."
 - b. On all sections and elevations, clearly identify the Datum Point and provide references to building height based on the Datum Point.
 - c. Retaining walls shall not be used to raise the effective elevation of the finished grade for purposes of measuring the height of a building or structure.
2. The height of the building in the R1, RS, or RE9 zone is limited to 28 ft. when the roof slope at any portion of the roof is less than 25%, and 33 ft. when the slope is equal to or greater than 25%. (12.21.1)
3. The height of the building in the RA, RE11, RE15, RE20 or RE40 zones is limited to 30 ft. when the roof slope at any portion of the roof is less than 25%, and 36 ft. when the slope is equal to or greater than 25%. (12.21.1)
4. In the R1V(_____) zone, show that all Buildings and Structures do not exceed the maximum allowed height of (_____) ft. (Table 12.08C.5(b))
5. Show that all Buildings and Structures in the R1F(_____) R1R(_____) zone do not exceed the maximum allowed front mass height of (_____) ft. for a front envelope depth, measured from the front yard setback, of (_____) ft. (Table 12.08 C.5(c)&(d))
6. Show that all Buildings and Structures in the R1F(_____) R1R(_____) zone do not exceed the maximum allowed rear mass height of (_____) ft. for a rear envelope depth, measured from the rear yard setback, of (_____) ft. (Table 12.08 C.5(c)&(d))
7. Projecting roof structure (_____) exceeds the projection height of (_____) ft. and setback (_____) ft. as allowed per 12.21.1.B.

B. ENCROACHMENT PLANE

1. The encroachment plane (see diagram to the right) is defined as an invisible inclined plane sloping inward at a forty-five degree angle from the vertical extension of the required front and side yard setbacks that originates at a specified height.
 - a. A building may not intersect the encroachment plane.

- b. The encroachment plane restriction does not apply to roof structures and equipment as allowed by Section 12.21.1 B.3.
 - c. For the purpose of encroachment plane, height shall be measured from the existing or finished grade, whichever is lower, along the required front and side yard setbacks.
 - d. Clearly identify the encroachment plane on all elevations and sections.
2. In the R1 zone, show that all Buildings and Structures do not project beyond the Encroachment Plane Height with an Encroachment Plane Origin Height of 20 ft. (12.08C.5(a))
 3. In the R1V(_____) R1F(_____) R1R(_____) zone, show that all Buildings and Structures do not project beyond the Encroachment Plane with an Origin Height of (_____) ft. (Table 12.08 C.5(b),(c)&(d))
 4. The projection of (eave) (parapet) (_____) is not an allowable projection beyond the Encroachment Plane. See Section 12.21.1 B.3 for allowable projections.

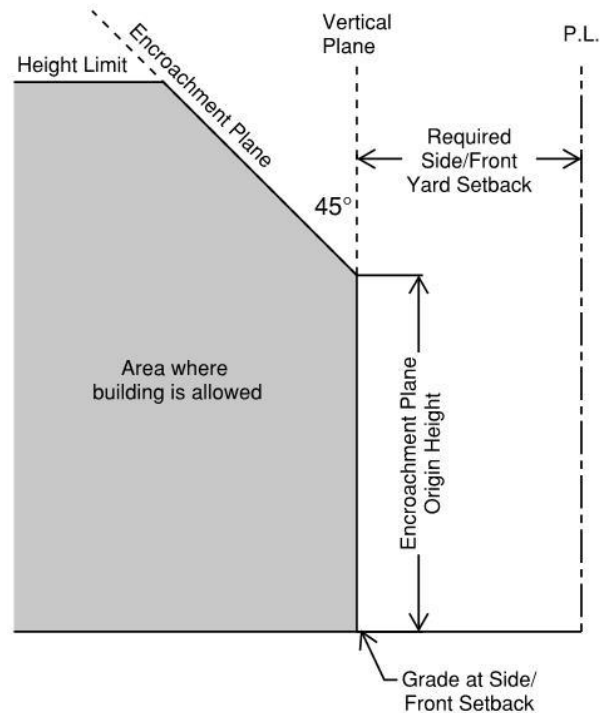

Figure 12.03-1: Encroachment Plane diagram

