

# DETACHED CARPORT

Minimum construction requirements when located outside of a fire district

**NOTE:**

Refer to Wood Frame Prescriptive Provisions (P/BC 2023-004) for specifications of concrete, lumber grade, and rafter spacing.

Provide plot plan showing the location of all existing buildings on lot with dimensions to lot lines and between buildings.

Carport to observe a minimum 5' distance to property lines and/or building separation.

The carport structure shall comply with all applicable zoning regulations.

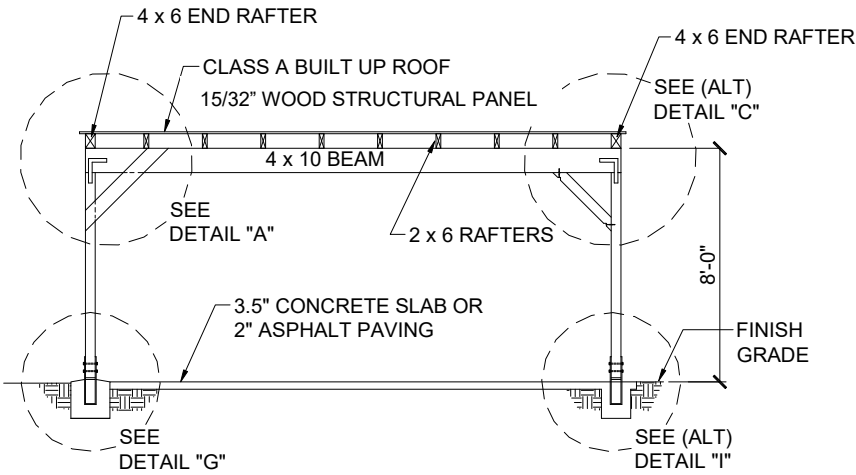

SIDE VIEW

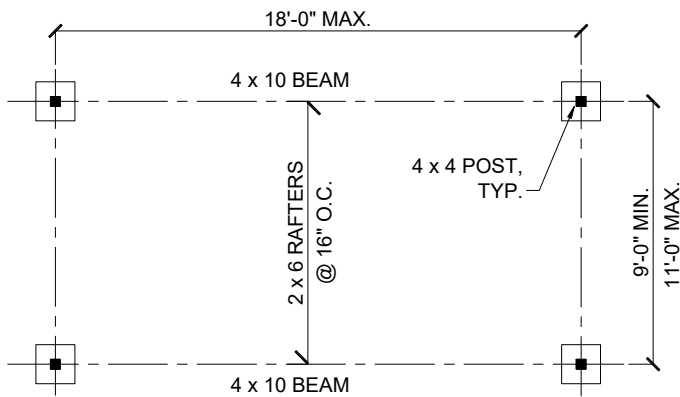

FOOTING PLAN  
(1-CAR CARPORT)

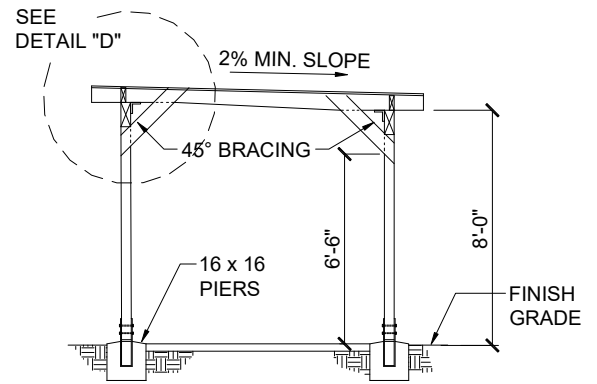

END VIEW

As a covered entity under Title II of the Americans with Disabilities Act, the City of Los Angeles does not discriminate on the basis of disability and, upon request, will provide reasonable accommodation to ensure equal access to its programs, services and activities. For efficient handling of information internally and in the internet, conversion to this new format of code related and administrative information bulletins including MGD and RGA that were previously issued will also allow flexibility and timely distribution of information to the public.

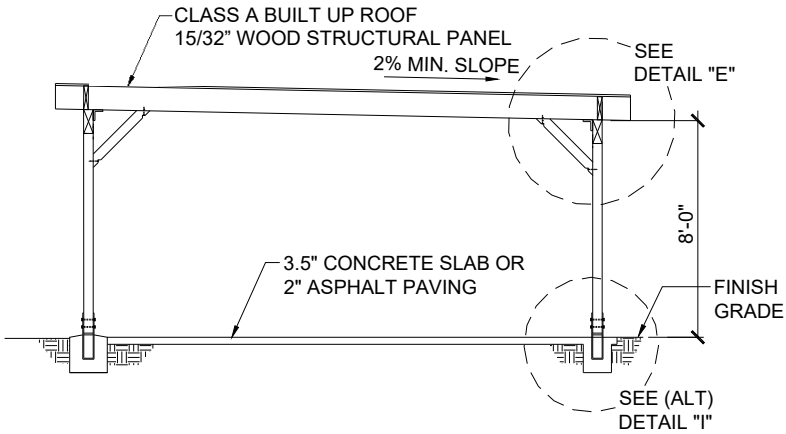

**EXTERIOR SIDE VIEW**

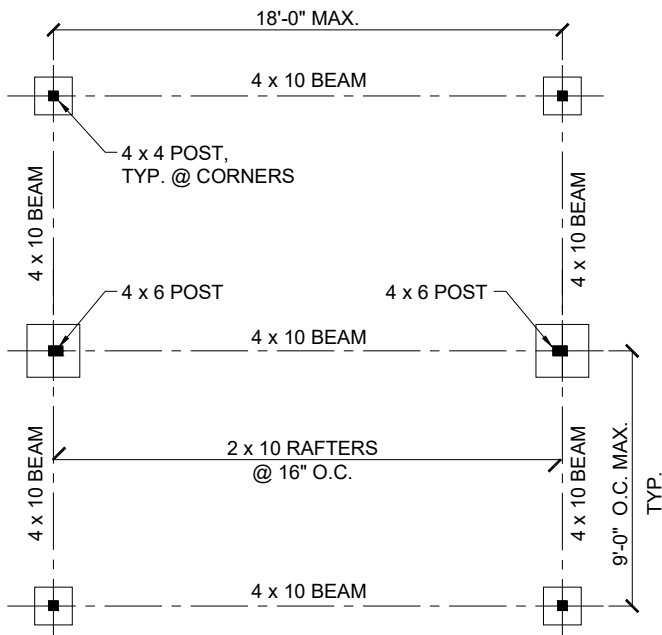

**FOOTING PLAN**  
(2-CAR CARPORT)

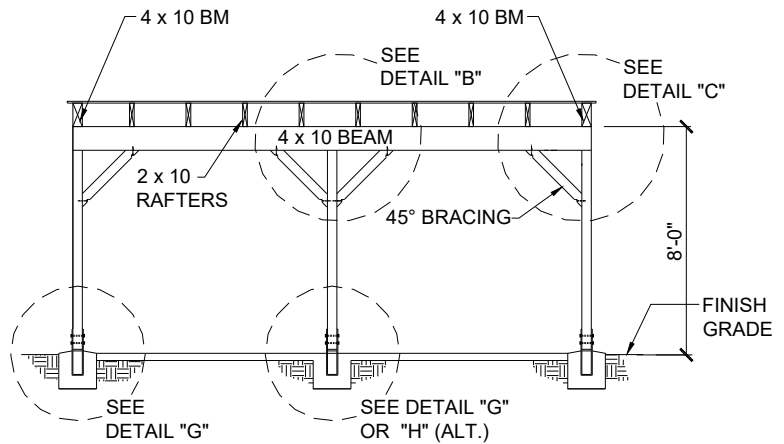

**END VIEW**

As a covered entity under Title II of the Americans with Disabilities Act, the City of Los Angeles does not discriminate on the basis of disability and, upon request, will provide reasonable accommodation to ensure equal access to its programs, services and activities. For efficient handling of information internally and in the internet, conversion to this new format of code related and administrative information bulletins including MGD and RGA that were previously issued will also allow flexibility and timely distribution of information to the public.

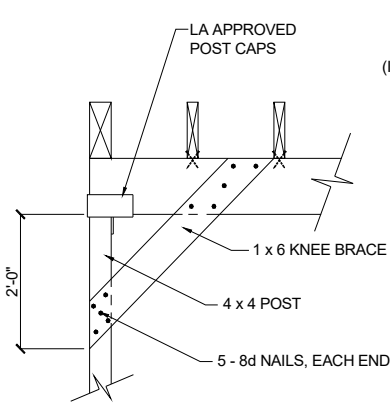

**DETAIL "A"**

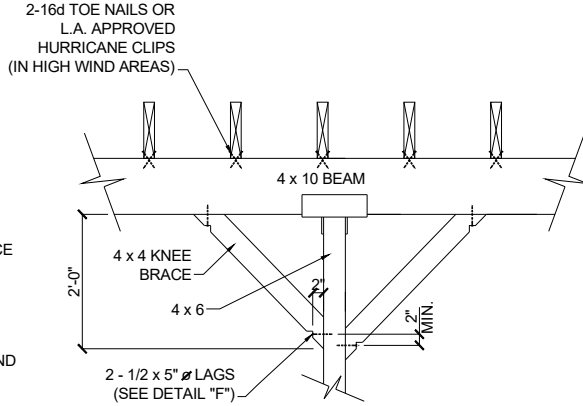

**DETAIL "B"**

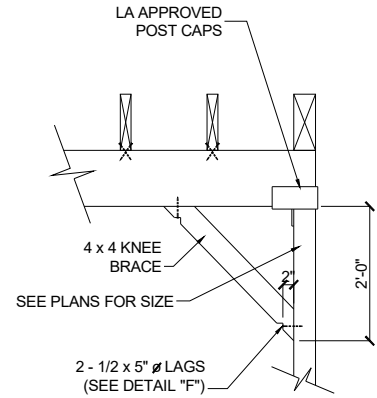

**DETAIL "C"**

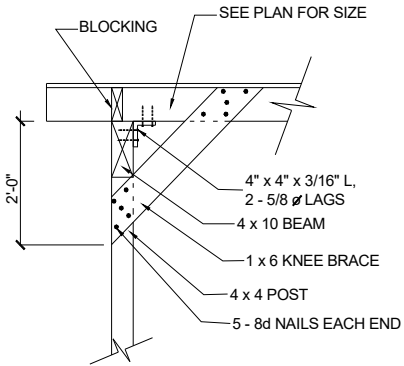

**DETAIL "D"**

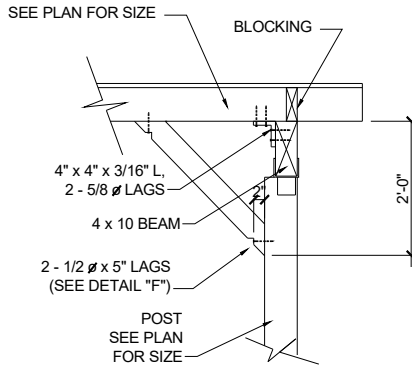

**DETAIL "E"**

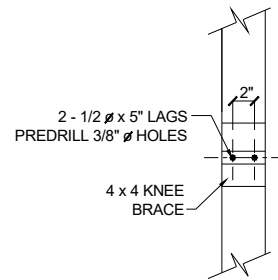

**DETAIL "F"**

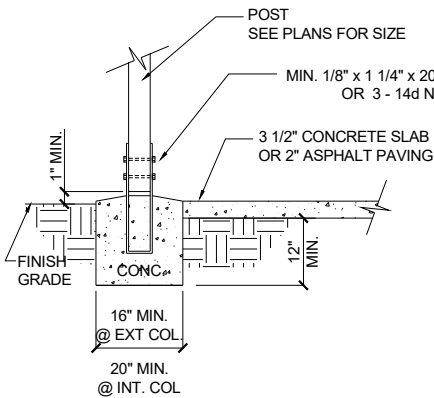

**DETAIL "G"**

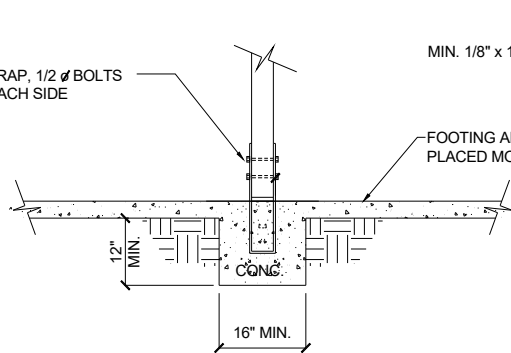

**DETAIL "H"**

(ONLY ALTERNATIVE FOR HIGH WIND AREAS)

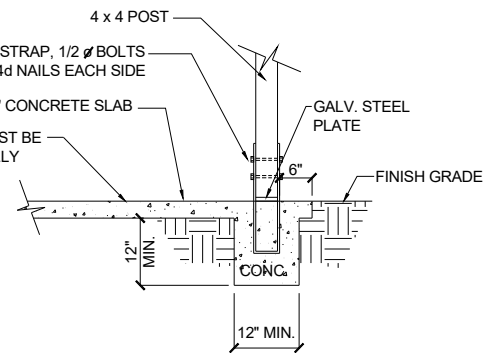

**DETAIL "I"**

(ONLY ALTERNATIVE FOR HIGH WIND AREAS)

As a covered entity under Title II of the Americans with Disabilities Act, the City of Los Angeles does not discriminate on the basis of disability and, upon request, will provide reasonable accommodation to ensure equal access to its programs, services and activities. For efficient handling of information internally and in the internet, conversion to this new format of code related and administrative information bulletins including MGD and RGA that were previously issued will also allow flexibility and timely distribution of information to the public.

Wood Frame Prescriptive Provisions is a classification of buildings by construction materials and methods. It is the least restrictive construction type permitted by the Los Angeles Building Code and includes light, wood-frame construction. These sheets are for information and reference only and is not a substitute for accurate drawings prepared for each proposed construction project.

## **FOOTINGS ON EXPANSIVE SOILS**

Footing systems on expansive soil shall be constructed in a manner that will minimize damage to the structural from movement of the soil.

1. Depth of footings below the natural and finished grades shall not be less than 24 inches for exterior and 18 inches for interior footings.
2. Exterior walls and interior bearing walls shall be supported on continuous footings.
3. Footings shall be reinforced with four 1/2-inch diameter deformed reinforcing bars. Two bars shall be placed 4 inches from the bottom of the footing and two bars within 4 inches from the top of the footing.
4. Concrete floor slabs on grade shall be placed on a 4-inch fill of coarse aggregate or on a moisture barrier membrane. The slabs shall be at least 3-1/2 inches thick and shall be reinforced with 1/2" diameter deformed reinforcing bars. Reinforcing bars shall be spaced at intervals not exceeding 16 inches each way.
5. The soil below an interior concrete slab shall be saturated with a moisture to a depth of 18 inches prior to placing the concrete.

## **CARPORT COVER ENCLOSURE**

The carport cover must remain open. In the event the carport cover is enclosed due to the requirement of fire separation distance per Table R302.1(1) of LARC, then the carport cover shall be designed in accordance with the requirements of Wood Frame Prescriptive Provisions (Information Bulletin P/BC 2023-004) or structural calculations must be provided to satisfy the lateral design requirements of the LABC.