



SOUND-RATED PARTITIONS AND FLOOR-CEILING CONSTRUCTION

In accordance with Section 1207.9.1 and Section 1207.10 of the Los Angeles Building Code (LABC), walls and floor ceiling assemblies separating dwelling units or guest rooms from each other and from public or service areas (such as interior corridors, garages, and mechanical spaces) shall provide airborne sound insulation for walls, and both airborne and impact sound insulation for floor-ceiling assemblies.

Partitions and floor-ceiling assemblies constructed in accordance with the diagrams shown herein are considered to have Sound Transmission Class (STC) ratings and Impact Insulation Class (IIC) ratings of 50 as shown. They may be used to meet the acoustically rated construction requirements stipulated in Sections 1207.10 and 1207.11 of the LABC. Other assemblies may be used provided that they comply with the requirements of Section 1207.12 of the LABC. Laboratory and field tests to establish general approvals require an STC rating of 50 for walls and floors and an IIC rating of 50 for floors. The specified rating of 45 for field-tested assemblies (noted in Section 1207.10 of the LABC) is to be used for acceptance of individual jobs only.

The following notes shall be provided on the plans or in their contents delineated as details on the plans.

1. All penetrations into sound rated partitions or floor-ceiling assemblies shall be sealed, lined, or insulated with an approved permanent resilient sealant.
2. All rigid conduits, ducts, plumbing pipes, and appliance vents located in sound rated assemblies shall be isolated from the building construction by means of resilient sleeves, mounts, or a minimum 1/4" thick approved resilient material.
3. An approved permanent and resilient acoustical sealant shall be provided along the joint between the floor and the separation walls.
4. Metal ventilating and conditioned air ducts located in sound rated assemblies shall be lined (Exception: Ducts serving only exit ways, kitchen cooking facilities, and bathrooms need not be lined).
5. Mineral fiber insulation shall be installed in joist spaces whenever a plumbing, piping, or duct penetrates a floor-ceiling assembly or where such unit passes through the plane of the floor-ceiling assembly from within a wall. The insulation shall be installed to a point 12" beyond the pipe or duct. This requirement is not applicable to fire sprinkler pipe, gas line or electrical conduit.
6. Electrical outlet boxes in opposite faces of separation walls shall be separated horizontally by 24" and note that back and sides of boxes shall be sealed with 1/8" resilient sealant and backed by a minimum of 2" thick mineral fiber insulation.
7. No wall furnace shall be installed in sound rated partitions.
8. No electrical panel shall be installed in sound rated partitions.

STANDARD SOUND RATED FLOOR - CEILING ASSEMBLIES

STC 50 - IIC 50 FIRE RATING AS SHOWN

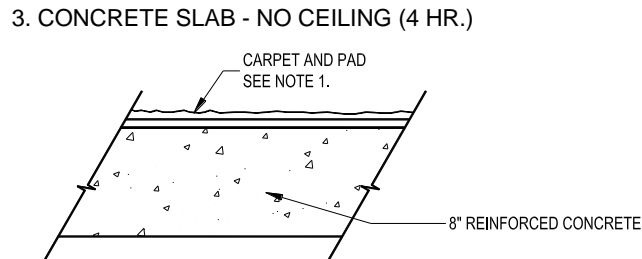
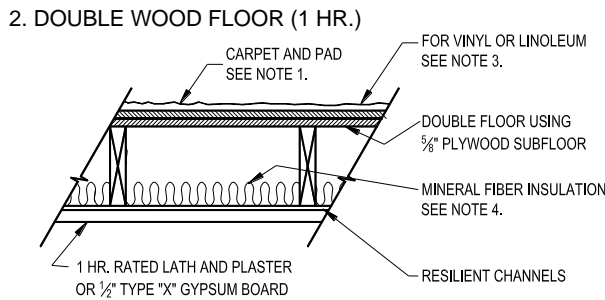
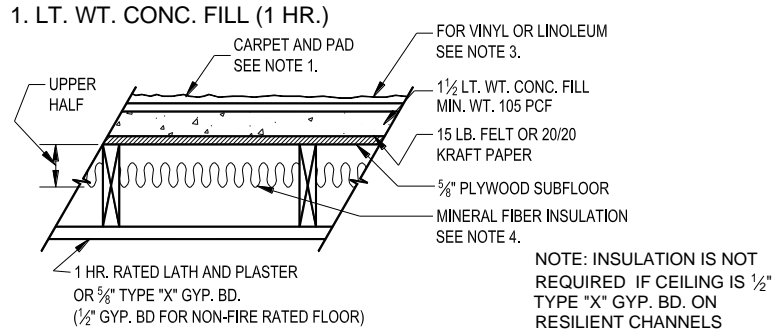

4. CONCRETE SLAB - WITH CEILING (2 HR.)

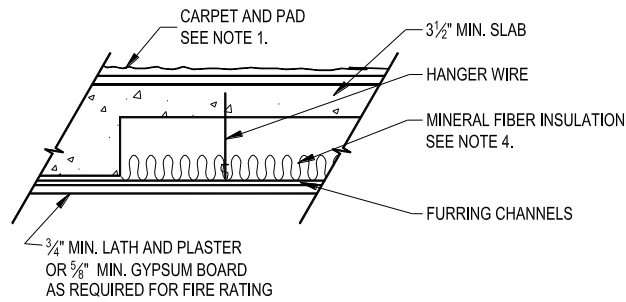

5. LT WT. CONC. FILL (2 HR.)

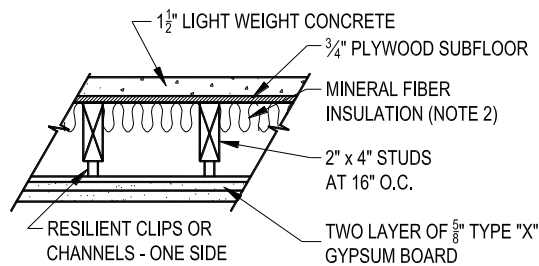

GENERAL NOTES:

1. 13 oz. face wt. carpet (31 oz. tot) and 40 oz. juttad pad, or 48 oz. foam rubber, or 3/8" rebonded urethane foam (4 pcf), or 1/2" urethane foam (2.4 pcf).
2. Type and spacing of resilient channels and the attachment of channels and gypsum board or lath shall be as required for fire ratings.
3. Sheet vinyl and linoleum floor coverings with 1/8" minimum thickness resilient backing may be substituted for carpet and padding in kitchen and bathroom areas, if ceilings are on resilient channels.
4. The mineral fiber insulation shall have a thermal resistance R value of 11 or greater as determined by Federal Specification HH-I-521E.

STANDARD SOUND RATED PARTITION ASSEMBLIES

STC 50 – FIRE RATING AS SHOWN

1. 1 HR. FIRE RATING

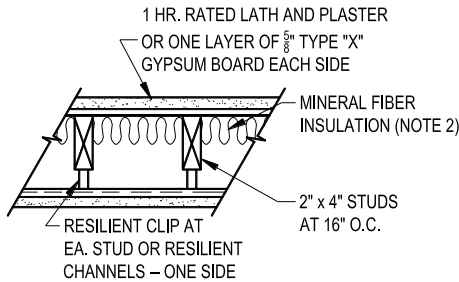

2. 1 HR. FIRE RATING

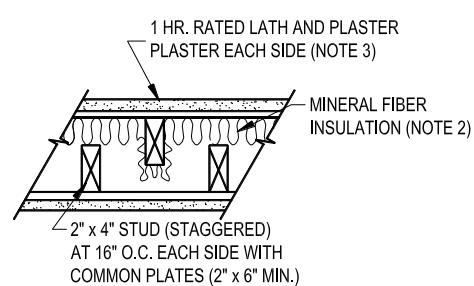

3. 2 HR. FIRE RATING

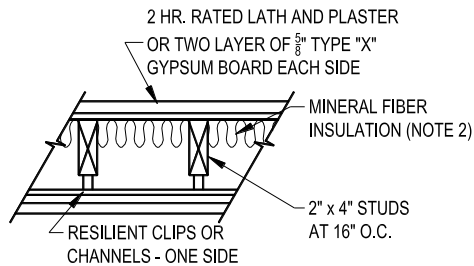

4. 2 HR. FIRE RATING

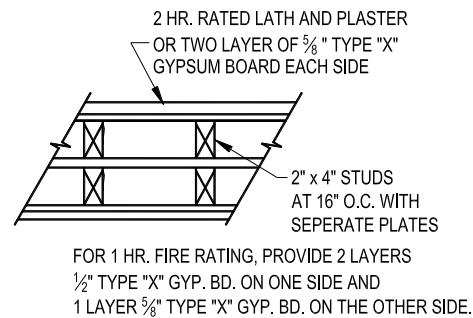

5. 2 HR. FIRE RATING

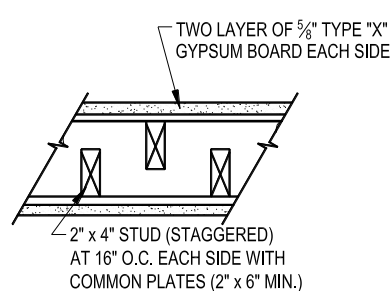

6. 2 HR. FIRE RATING

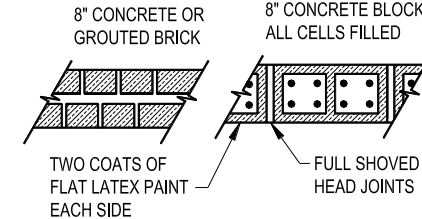

GENERAL NOTES:

1. The type and spacing of resilient channels and clips and the attachment of gypsum board or lath shall be as required for fire ratings.
2. The mineral fiber insulation shall have a thermal resistance R value of 11 or greater as determined by Federal Specification RR-I-521B.
3. No test is on file to justify an STC 50 with one 5/8" type "X" gypsum board each side.

FIRE RATED FLOOR-CEILING ASSEMBLIES USING METAL FRAMING

STC 50 - IIC 50 FIRE RATING AS SHOWN

1. ONE HOUR FIRE RATED PARTITION

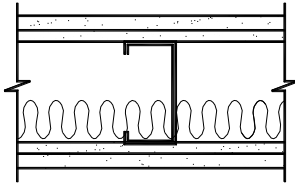

One layer 1/2" type "X" gypsum wallboard or veneer base applied parallel to one side of min. 2 1/2" No. 25 gauge metal studs 24" o.c. with 1" type "S" drywall screws 8" o.c. 2" mineral fiber 2.5 pcf friction fit in stud space. Two layers 1/2" type "X" gypsum wallboard or veneer base applied on other side parallel to studs with 1" type "S" drywall screws 36" o.c. in base layer and 1 5/8" type "S" drywall screws in face layer 12" o.c. stagger joints 24" o.c. each layer and side.

2. ONE HOUR FIRE RATED PARTITION

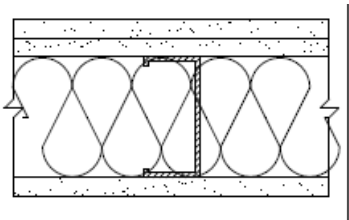

One layer 1/2" Type "X" plain or predecorated gypsum wallboard applied parallel to one side of min. 2 1/2" No. 25 gauge steel studs 24" o.c. with 1" type "S" drywall screws 8" o.c. at vertical joints and 3/8" adhesive beads at intermediate studs. **OPPOSITE SIDE: BASE LAYER** 1/2" type "X" gypsum wallboard applied parallel to studs with 1" type "S" drywall screws 8" o.c. at vertical joints and 12" o.c. at intermediate studs. **FACE LAYER** 1/2" Type "X" plain or predecorated gypsum wallboard applied parallel to studs with 1 5/8" type "S" drywall screws 8" o.c. at vertical joints and 5/8" adhesive beads at intermediate studs. Joints staggered 24" each layer and side. Sound tested with 3 1/2" glass fiber insulation friction fit in stud space and all layers screw attached without adhesive.

3. TWO HOUR FIRE RATED PARTITION

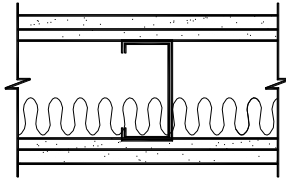

BASE LAYER 1/2" type "X" gypsum wallboard or veneer base applied parallel to each side of min. 2 1/2" No. 35 gauge metal stud 24" o.c. with 1" type "S" drywall screws 12" o.c. **FACE LAYER** 1/2" type "X" gypsum wallboard or veneer base applied on each side parallel to studs with 1 5/8" type "S" drywall screws 12" o.c. stagger joints 24" o.c. each layer and side. Sound tested using 1 1/2" mineral fiber in stud space.

4. ONE HOUR FIRE RATED PARTITION

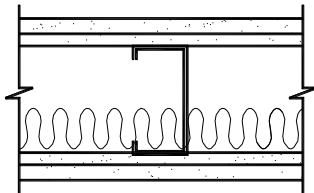

Min. 2 1/2" No. 25 gauge metal studs 24" o.c. max. 3/8" type "X" gypsum lath attached to studs each side with 1" self drilling screws, two per panel width per stud. 1/2" gypsum and sand plaster; 1 1/2" mineral fiber insulation 2.5 pcf. **Alternate:** Attach gypsum lath with resilient clips.

5. TWO HOUR FIRE RATED PARTITION

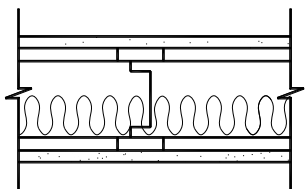

Min. 2 1/2" No. 25 gauge metal studs 16" o.c., 3/8" type "X" gypsum lath attached to studs each side with resilient clips, 3/4" perlite or vermiculate gypsum plaster; 1 1/2" mineral fiber insulation 2.5 pcf.

6. Two hour fire rated ceiling

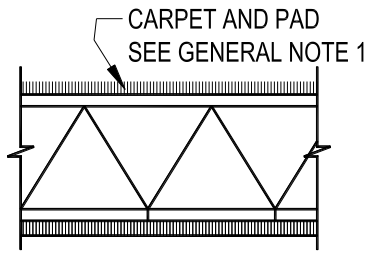

1/2" gypsum lath 1/2" plaster, one layer 1/2" type "X" gypsum wallboard or one layer 1/2" veneer base applied at right angles to screwable furring channels with 1" type "S" drywall screws 12" o.c. furring channels 24" o.c. attached with 18 gage wire ties 48" o.c. to open web joists 24" o.c. supporting 3/8" rib metal lath or 9/16" deep, 28 gage corrugated steel and 2 1/2" concrete slab measured from top flute. Double channel at wall board end joints.

7. One hour fire rated chase wall

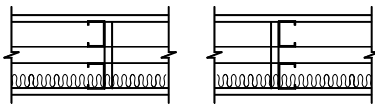

5/8" type "X" gypsum wallboard or veneer applied parallel to a double row of 1 5/8" metal studs 24" o.c. and 6 1/3" apart with 1" type "S" drywall screws 8" o.c. at edges and top and bottom runners, 12" o.c. in field. Stagger joints 24" each side, 25 ga. X 9 1/2" long runner pieces located at 1/3" points used as cross braces and attached with two No. 8 X 1/2" self-drilling steel screws at each end. Optionally 5/8" gypsum board pieces 12" wide X 9 1/2" long may be used as cross braces fastened to stud pairs with three 1" type "S" drywall screws at each end of brace. Sound tested using 3 1/2" glass fiber staples to one side in cavity.

8. Two hour fire rated chase wall

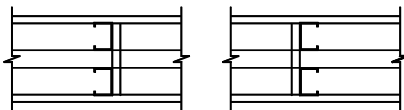

BASE LAYER 5/8" type "X" gypsum wallboard or veneer base applied parallel to a double row of 1 5/8" metal studs 24" o.c. and 6 1/4" apart with 1" type "S" drywall screws 8" o.c. at edges, 12" o.c. in field. 25 gage by 9 1/2" long runner pieces located at 1/3" points used as cross braces and attached with two No. 8 X 1/2" self-drilling steel screws at each end. Optionally 5/8" type "X" gypsum board pieces 12" wide x 9 1/2" long may be used as cross braces fastened to stud pairs with three 1" type "S" drywall screws at each end of brace. **FACE LAYER** 5/8" type "X" gypsum wallboard veneer base applied parallel to studs with 1 5/8" type "S" drywall screws 8" o.c. at joints and top and bottom runners, 12" o.c. in field. Stagger joints each layer and side.

GENERAL NOTES:

All partitions and floors shall be caulked around the perimeter with a non-hardening caulking compound. For partitions a continuous bead of caulking shall be placed under the edge of the base layer of gypsum board or lath on each side of the partition.