

**6" CONCRETE BLOCK MASONRY WALL DETAIL
(6'-0" IN HEIGHT MAXIMUM)**

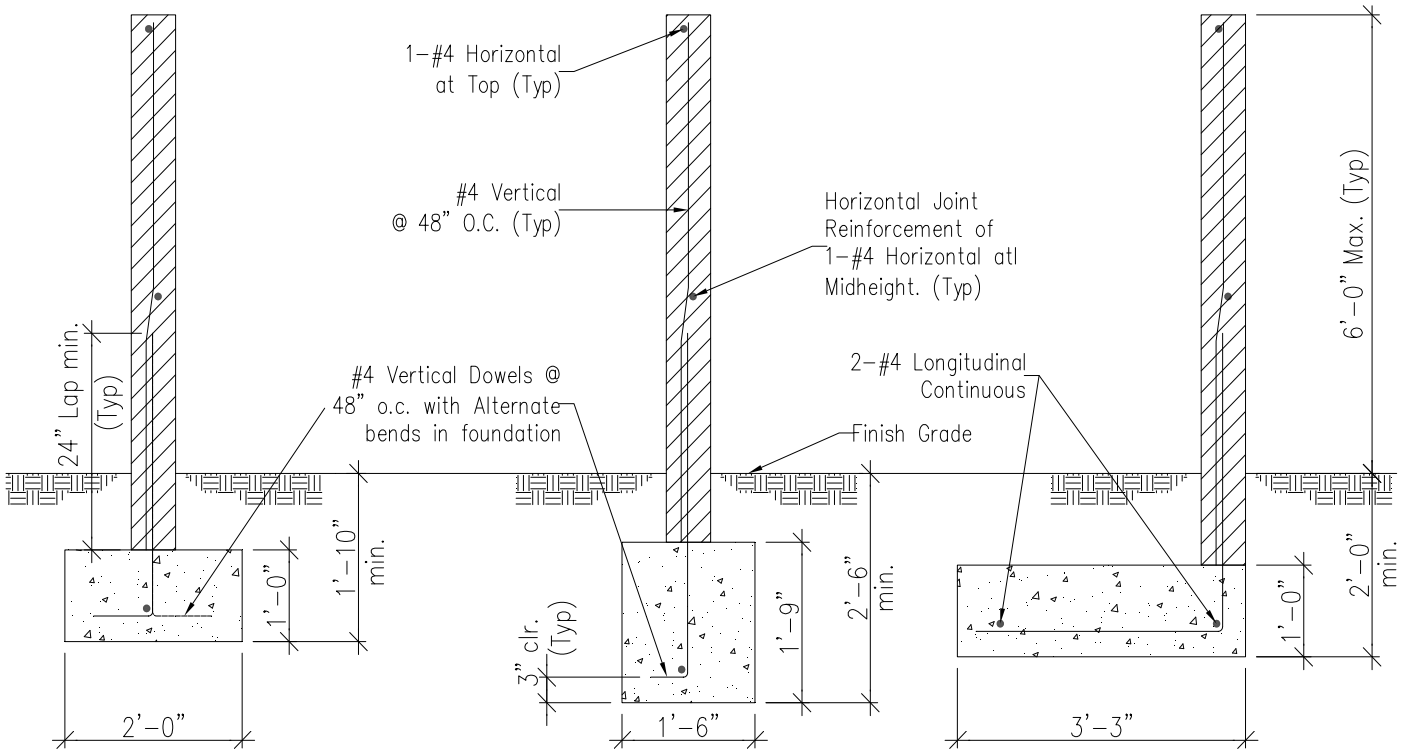

GENERAL SPECIFICATIONS:

1. Concrete mix for footing to be 1 part cement to 2.5 parts sand to 3.5 parts gravel with a maximum of 7.5 gallons of water per sack of cement/ Minimum $f'_c = 2,500$ psi.
2. Concrete block units shall conform to ASTM C90.
3. Reinforcing steel to be deformed and conformed to ASTM Standard A615 Grade 40 or Grade 60
4. Rebar shall be centered in the concrete block cell in which it is located
5. Concrete block units shall be placed in a running band with head joints in successive courses horizontally offset at least one-quarter the unit length.
6. Concrete block units to have vertical continuity of cells unobstructed. All cells containing reinforcing shall be solid grouted (vertical and horizontal reinforcement.)
7. Mortar mix for concrete to be 1 part cement to 0.5 part lime to 3 parts damp loose sand.
8. Grout mix for concrete block wall to be 1 part cement to 3 parts sand to which may be added not more than 0.1 part lime. Sufficient water to be added to produce consistency for pouring without segregation of constituents. The grout may contain 2 parts pea gravel, maximum size 3/8".
9. Block fence may be placed in the center of the "I" type foundation and at either edge to "L" type foundation.
10. A first inspection is required when trenches are ready for concrete and all required steel is tied in place. A second inspection is required when first horizontal bar and all vertical bars are in place but not grouted.
11. Foundation must be poured against undisturbed soil with no appreciable slope of sidewalls on all types of foundation.
12. Masonry or concrete fences over 3'-6" in height measured from adjacent grade shall require a building permit.
13. Height of fence shall comply with all provisions of the zoning code.