

Sewer Backwater Valves

July 16, 2009

Photos by:

Bobby Thompson,

Jeff Napier

Illustrations:

Rudy Martinez

Bobby Thompson

Presented by Jeff Napier

What is a Backwater Valve ?

A Backwater Valve is a one way valve that is installed on a building sewer to prevent the public/private sewer system from backing up and flooding a building due to:

- 1. An obstruction in the public or private sewer system, or;**
- 2. Storm drain overflow from heavy rains flooding the public sewer system.**

Sewer Backwater Valves

- Most properties are connected to public (mainline) sewers. The majority of these properties have been built so that an obstruction in the public sewer will not cause sewage backup into the property.
- Other properties; however, require the protection of a backwater valve in the owner's drain line. These properties were built with the lowest floor containing plumbing fixtures (bath tub, shower, etc.) below the upper manhole (maintenance hole) of the public sewer (see diagram in slide #7).
- The backwater valve is designed to automatically shut to prevent sewage from backing up into the building from an obstructed public sewer.

When is a Backwater Valve Required?

- Drainage piping serving fixtures on a floor, where the floor level is located **BELOW** the elevation of the next upstream manhole cover of the public/private sewer system, shall be protected from the backflow of sewage by installing an approved Backwater Valve. Section 710.1 UPC
 - NOTE: Fixtures located on a floor, where the floor level is located **ABOVE** the next uphill manhole cover elevation shall not discharge through a Backwater Valve.

Second Floor Bypasses Backwater Valve.

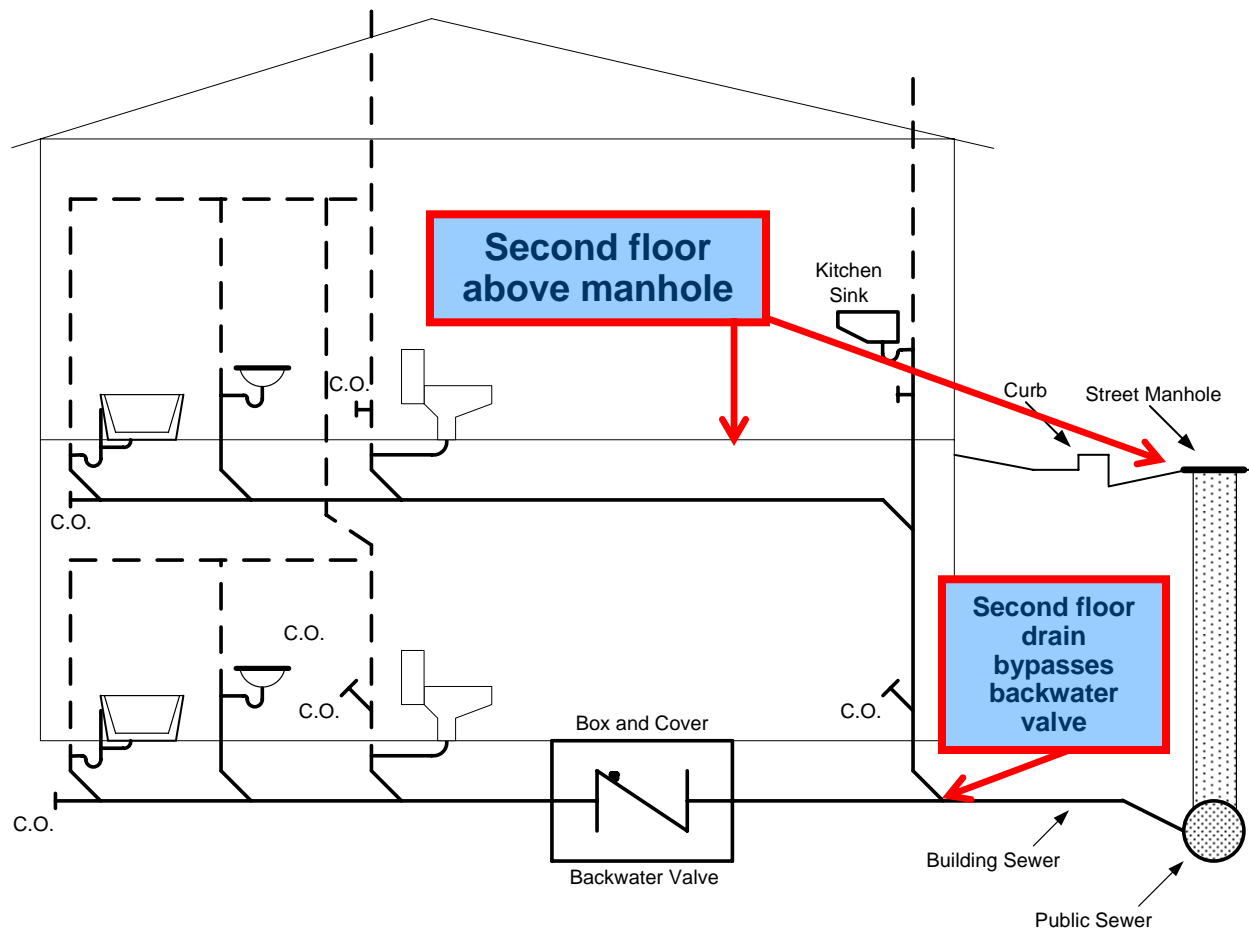

The Plumbing Code states:
when the **FLOOR** is located below the next uphill manhole cover.

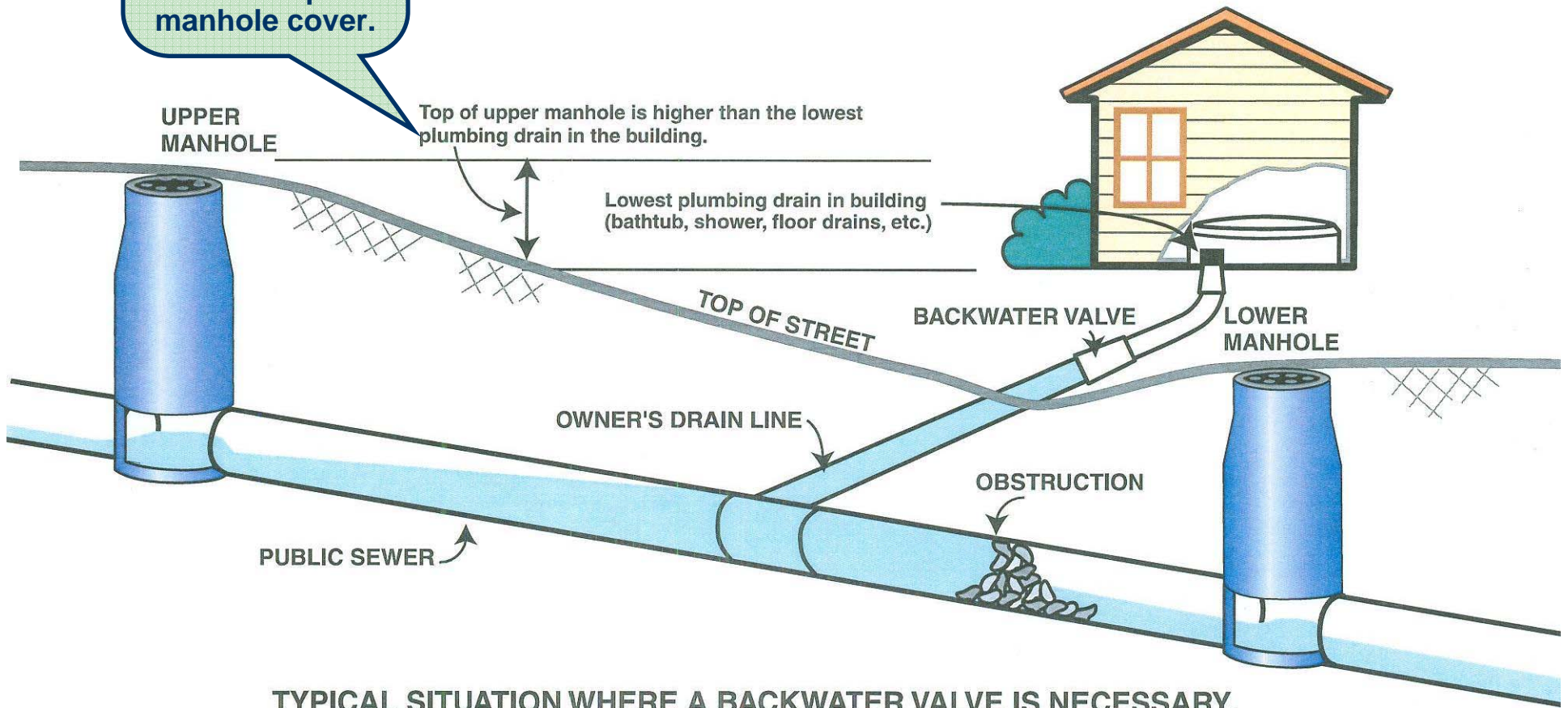

TYPICAL SITUATION WHERE A BACKWATER VALVE IS NECESSARY.

1. The floor is above first upstream manhole. Backwater Valve **NOT** required.

1. Backwater Valve NOT Required

2. Main floor would require an elevation to determine if a Backwater valve is required. Basement floor would require a Backwater Valve.

2.

3. All floors are located below first uphill manhole. Backwater Valve required.

3.

Backwater Valve REQUIRED

First Upstream Manhole

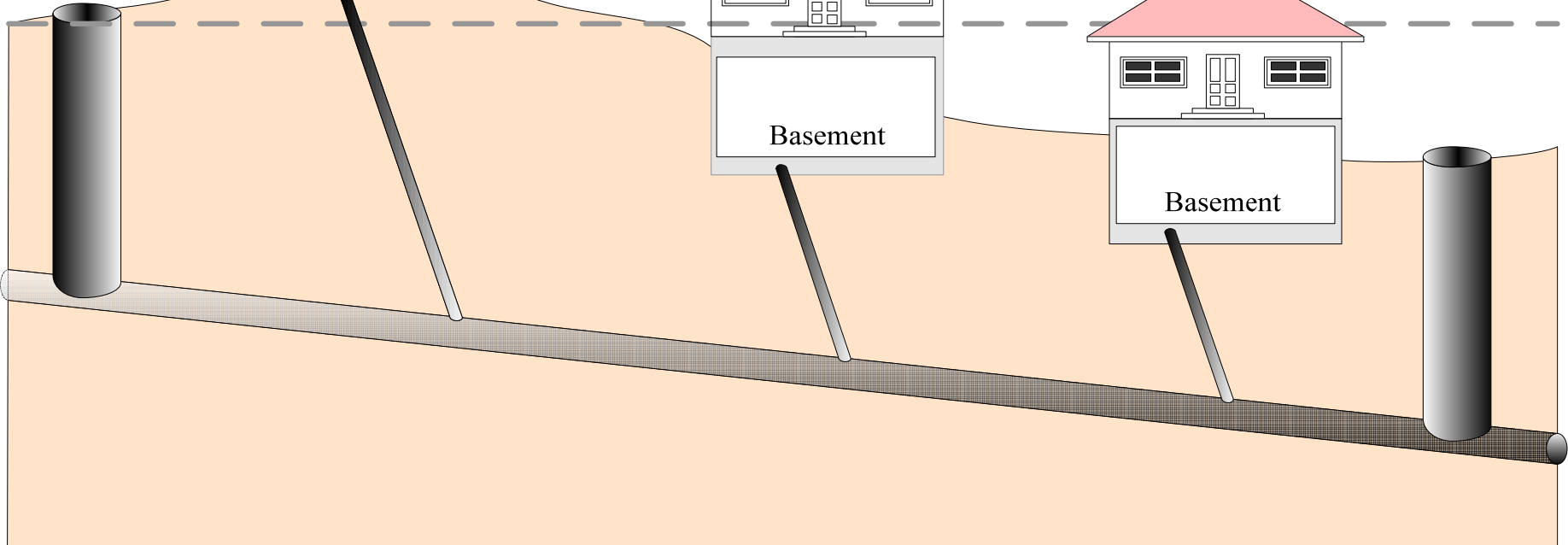



All homes with floor levels below this manhole need a Backwater Valve for protection against flooding.

Upper Manhole

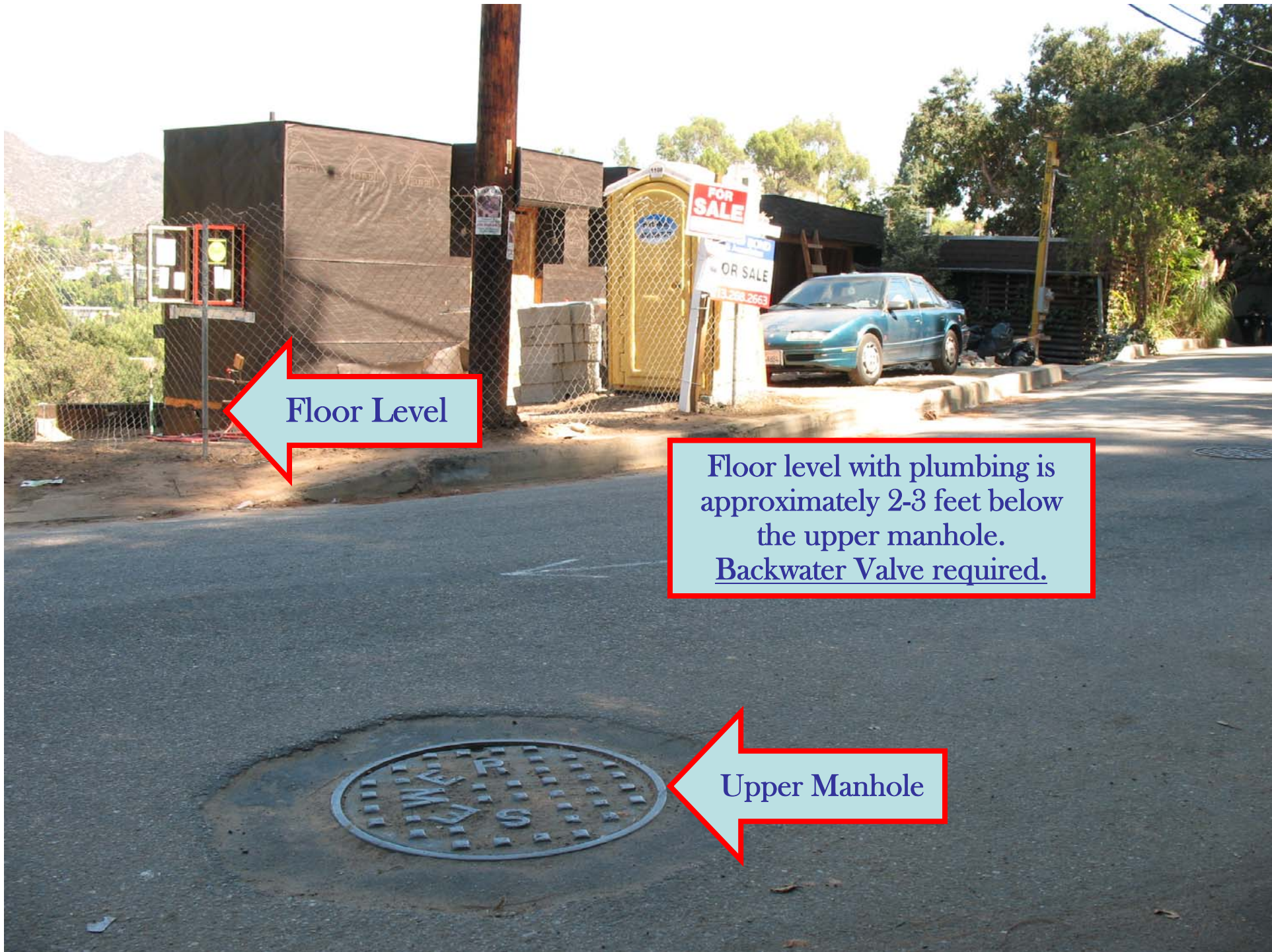

Floor Level

Floor level with plumbing is approximately 2-3 feet below the upper manhole.
Backwater Valve required.

Upper Manhole

Ground floors are below the upper manhole; Backwater Valve required if plumbing installed on these floors.

Upper Manhole

How Does A Backwater Valve Work?

A Backwater Valve has an internal mechanical disc (flapper) that will close a sewer pipe opening when reverse surcharges from a public/private sewer system attempt to enter into a building drainage system, preventing the flooding of a building with raw sewage.

How a Backwater Valve Works ...

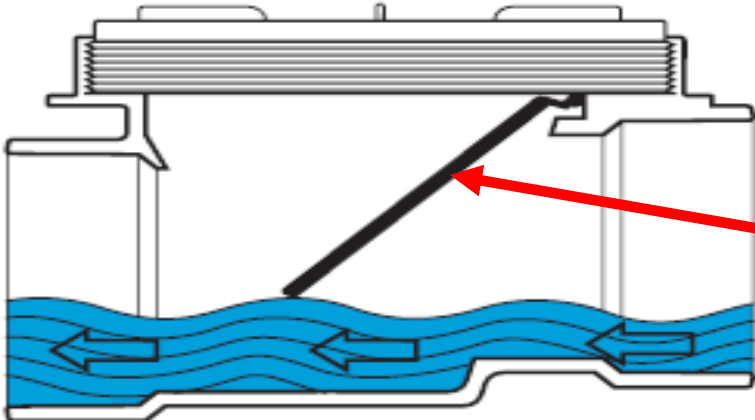

Backwater Valve is open - allowing waste waters to flow to sewers.

Flapper

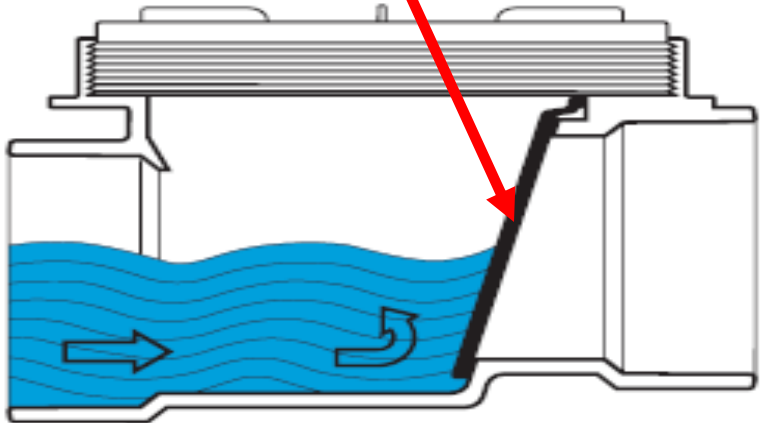

Backwater Valve is closed - protecting basement from sewer backups.

Examples

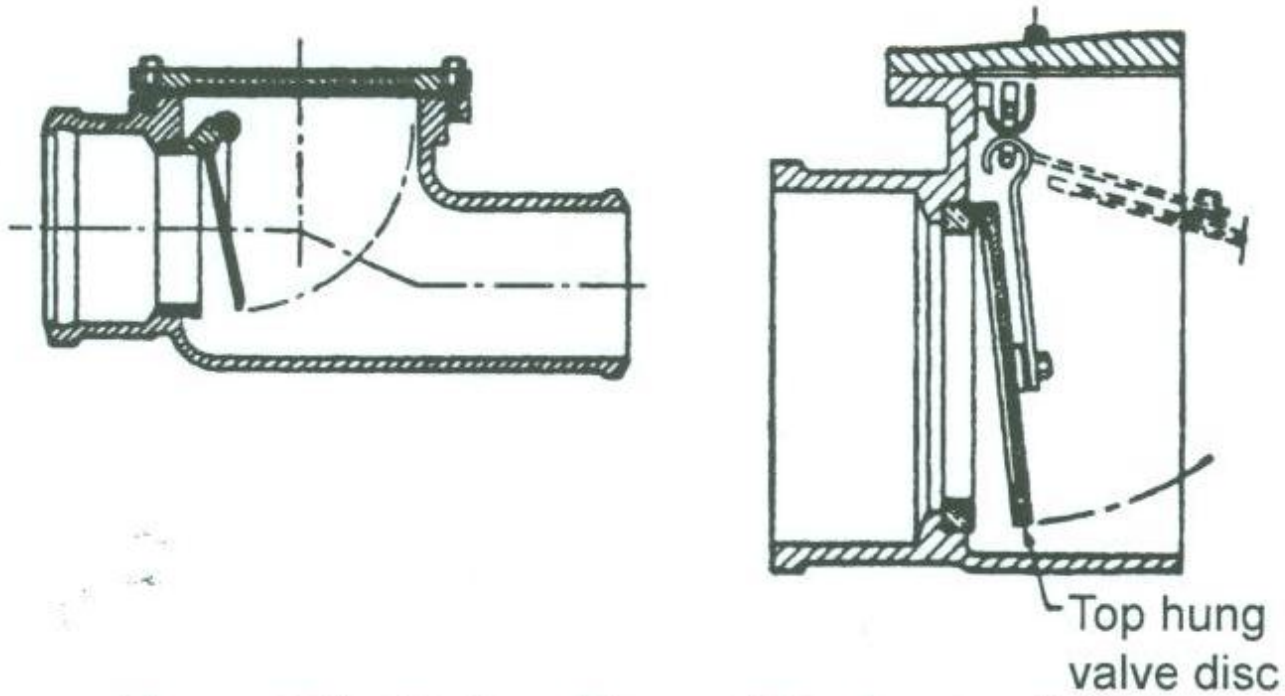
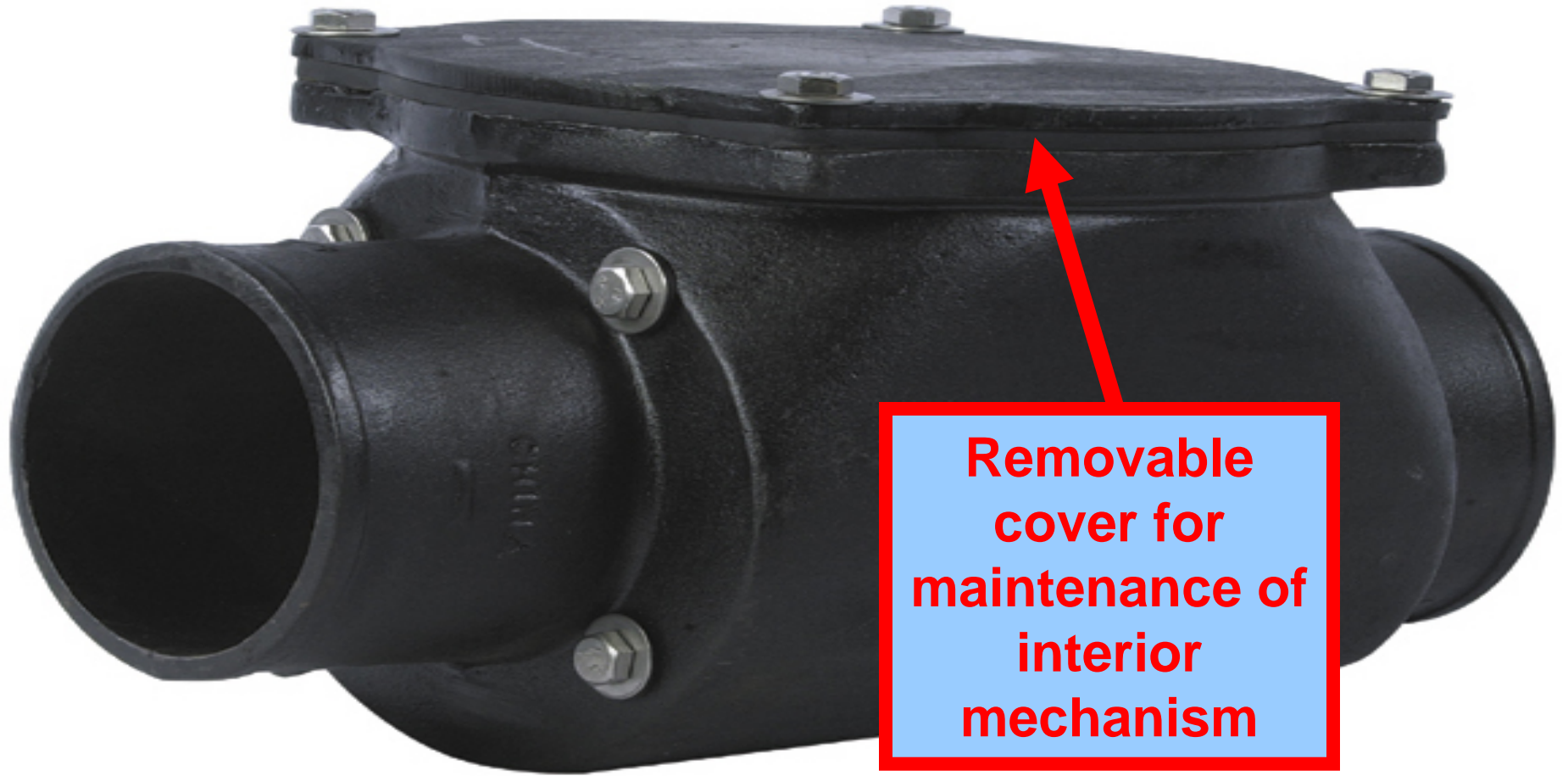
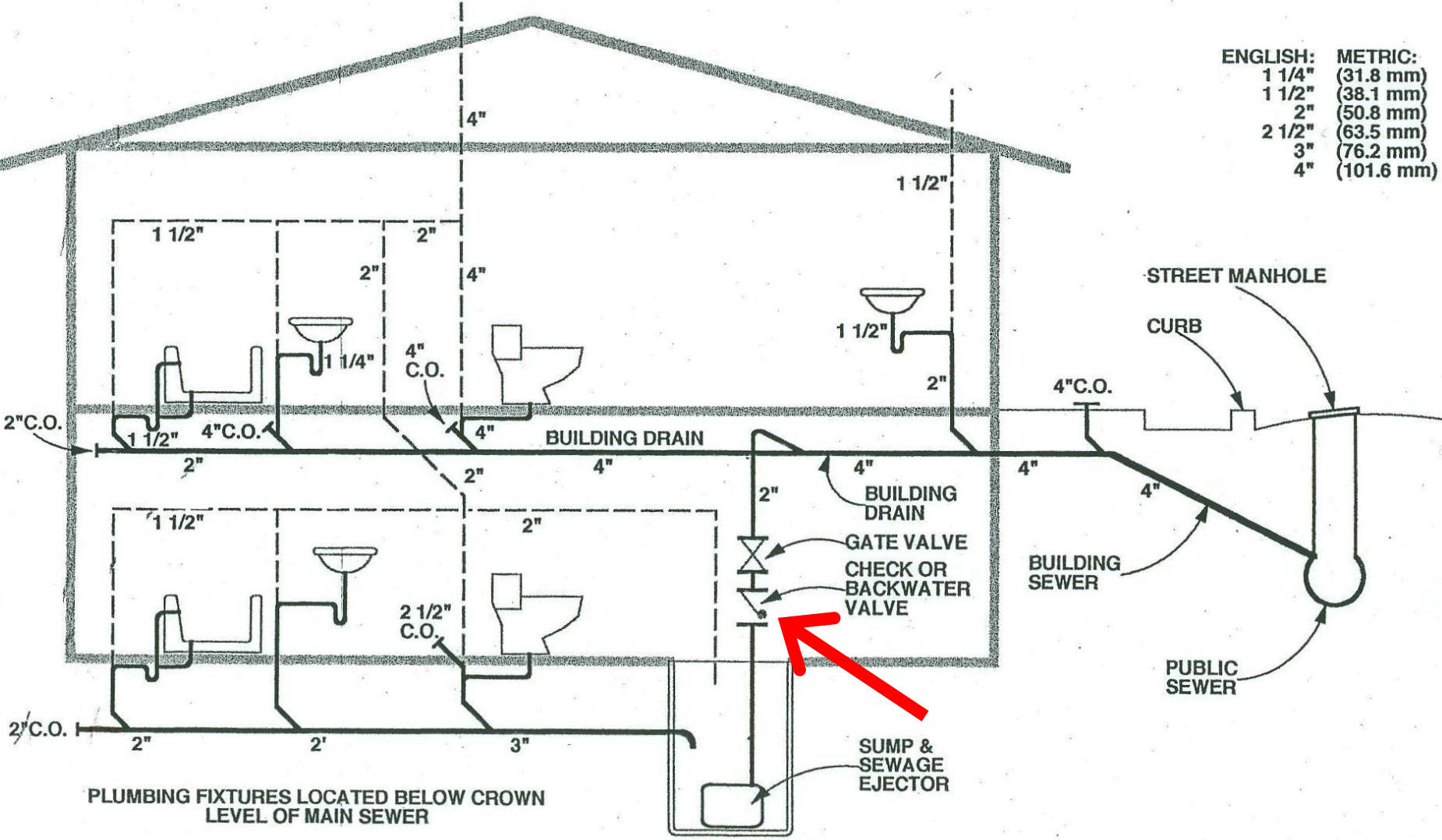

Figure 1-7 Various Types of Backwater Valve



**Removable
cover for
maintenance of
interior
mechanism**

ENGLISH:	METRIC:
1 1/4"	(31.8 mm)
1 1/2"	(38.1 mm)
2"	(50.8 mm)
2 1/2"	(63.5 mm)
3"	(76.2 mm)
4"	(101.6 mm)



PLUMBING FIXTURES LOCATED BELOW CROWN LEVEL OF MAIN SEWER

When a sewage ejector system is used, a Backwater Valve is required on the discharge line.

Backwater Valve Required to be Accessible

- Backwater Valves are required to be accessible and shall be enclosed by a masonry pit with an adequately sized waterproof cover.
- Remember that the retaining wall standard plan can be used if there is flat backfill and the cut does not exceed 4 ft. in depth.
- In some cases, a permit and building plan check may be required for pits deeper than 4 ft. and/or surcharges are placed on the walls.

Concrete Pit For Access and Repair

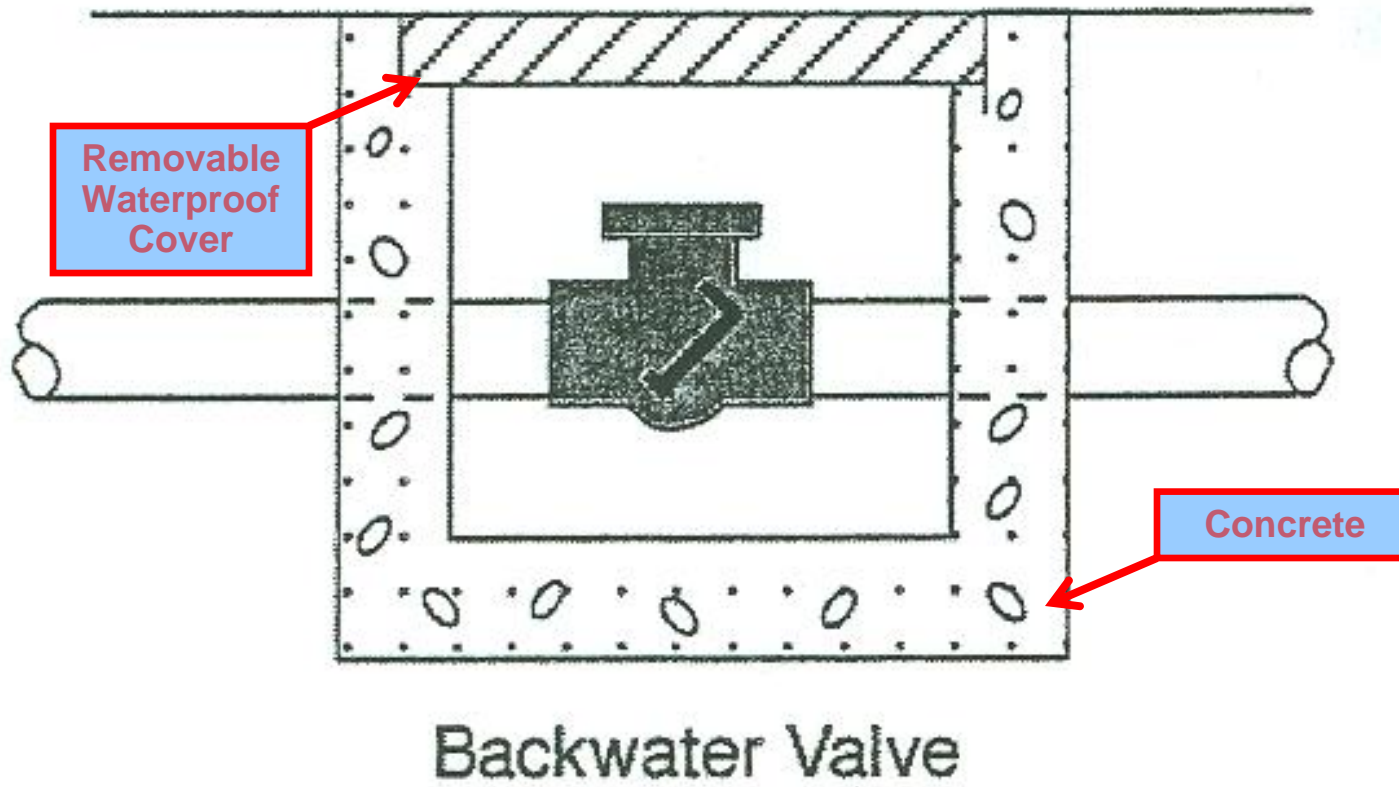

EXAMPLES OF PUBLIC OR
PRIVATE SEWER
SYSTEMS FLOODING
BUILDINGS WHERE
SEWER BACKWATER
VALVES WERE;

- 1) REQUIRED AND NOT
INSTALLED,
- 2) NOT PROPERLY
MAINTAINED AND FAILED









Summary

- Identify the Backwater Valve requirements in the early construction stages. For example...during the foundation stage, during ground work plumbing or sewer installation.
- Only fixtures on a floor that is below the upper manhole cover are to be protected by a Backwater Valve. All other fixtures shall bypass the Backwater Valve.
- Backwater Valves; when required, are to be installed on:
 - All new buildings with plumbing fixtures
 - Additions with floors below the next uphill manhole cover
 - Remodels over 50% cost of replacement value of the building
 - Sewer replacements

Summary

- If your property appears to require a backwater valve, but you do not know if one has been installed, we strongly encourage you to call a licensed plumber, who can evaluate your situation and, if necessary, install a backwater valve.
- Backwater valves must be checked to ensure that they are operating properly at all times. Root cleaning machines, debris in the drain line or other problems can easily damage or interfere with the proper operation of backwater valves.
- A plumbing permit is required for the installation of a backwater valve. For more information on obtaining a plumbing permit, see http://www.ladbs.org/permits/obtain_permit.htm
- For more information and contacts regarding sewer backwater valves, see http://www.lasewers.org/sewers/spills/backwater_valves.htm